

The MAX2644 Meets 10 μ sec Switching Time for 802.11b WLAN LNA

This application note measures the turn-ON turn-OFF time of the MAX2644 low-noise amplifier (LNA). This is needed to support IEEE 802.11b TDD WLAN systems. The system operates at 2.4GHz. The turn-ON time is 8.6 μ s, and the turn-OFF time is 5 μ s. The test set-up is shown along with oscilloscope and vector signal analyzer screen-plots.

Additional Information: [Wireless Product Line Page](#)
[Quick View Data Sheet for the MAX2644](#)
[Applications Technical Support](#)

Introduction

There are many competitive IEEE 802.11b wireless-local-area-network (WLAN) cards available in the market today. These WLAN cards operating at 2.4GHz unlicensed band are becoming increasingly popular in office or home environment, providing variable high data rate transfer up to 11Mbps. Perhaps, one very important parameter that distinguishes a product from its competition is the range performance, or simply put, the receiver sensitivity.

Superheterodyne receiver is predominantly the chosen architecture for WLAN cards available in the market today. Next generation of WLAN cards demands lower bill-of-material (BOM) cost. Direct conversion receivers are favored since expensive IF filters are eliminated and replaced by on-chip integrated lowpass filters for channel selectivity. Depending on the receiver architecture and fabrication processor chosen for the implementation, a low-noise amplifier (LNA) may be required to effectively lower the overall cascaded noise figure (NF) of the system, thus enhancing the range performance of the receiver.

The MAX2644, designed on a low-noise, advanced silicon-germanium (SiGe) technology, is an excellent choice for WLAN application at 2.4GHz. This low-cost, high third-order intercept point (IP3) LNA features a programmable bias, allowing the input IP3 and supply current to be optimized for specific applications. The LNA provides up to +1dBm input IP3 while maintaining a low-noise figure of 2.0dB and a typical gain of 16dB.

Since IEEE802.11b is a time-division duplexing (TDD) system, the LNA must have fast "Turn-

ON and OFF" time in order to fulfill system requirement. Typically, 10ms is an acceptable limit. Lab measurement indicates that the Turn-ON time for the MAX2644 is approximately 8.6ms (power ramping up from less than -30dBm to -13dBm \pm 1dB). The Turn OFF time is 5ms for 30dB drop from nominal output power. Both timings meet the system requirement of 10ms.

Table 1. The MAX2644 Switching Time Performance

	Settling Time	Test Condition
Turn ON Time	8.6 μ s	Output power settles to within \pm 1dB.
Turn OFF Time	5 μ s	Power level drops to -30dBc from nominal output power level.

Test Procedure

A standard MAX2644 Evaluation Kit was obtained and a low cost NPN digital transistor from Rohm (DTC144) was added to the bias network to allow for shutdown control as shown in Figure 1. The transistor logic high level is 2.7Vdc to turn ON. An equivalent FET switch could also be used for this application.

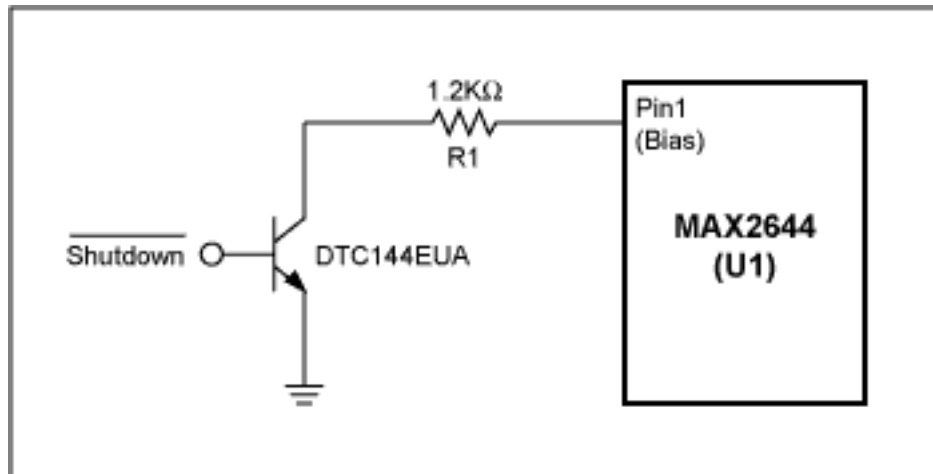

Figure 1. Standard EVKit modification

See Figure 2 for test setup utilized for all measurements.

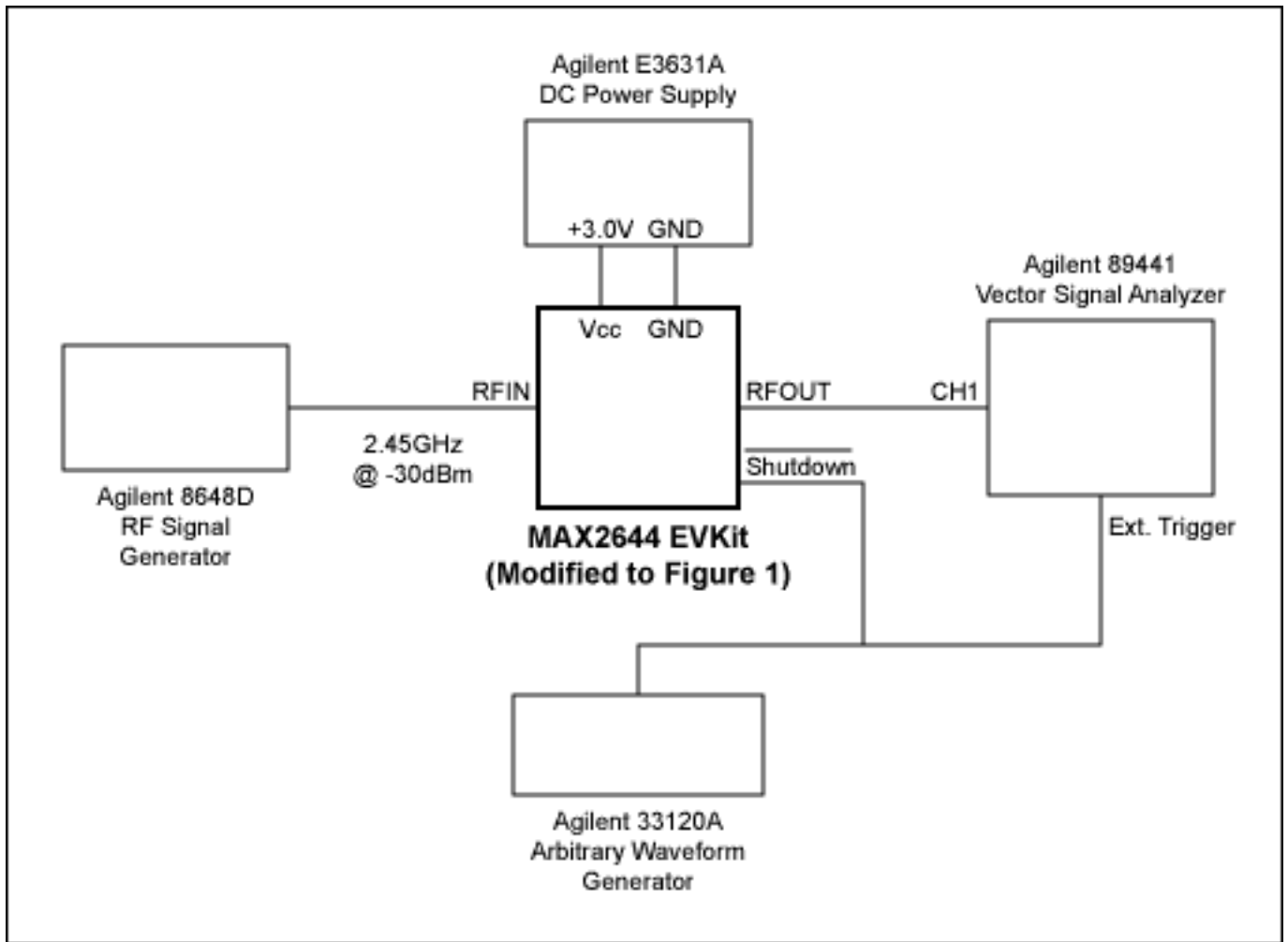

Figure 2. The MAX2644 switching time measurement test setup

The arbitrary waveform generator was set to deliver a TTL compatible logic pulse at 2.8V_{peak} in burst mode. The pulse-width is 62.5 μ S as shown in Figure 3.

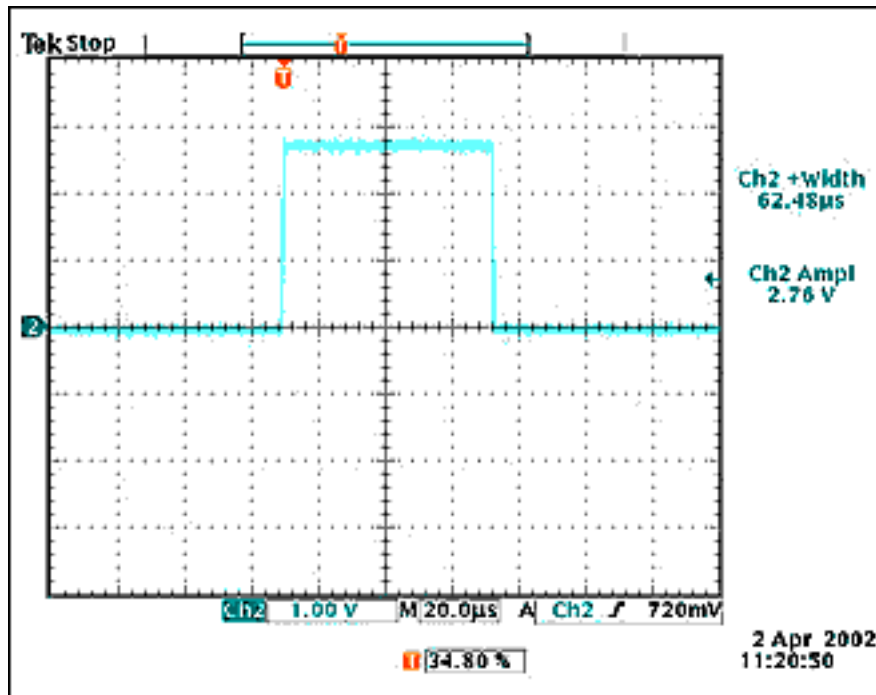

Figure 3. Trigger pulse applied to DTC144EUA digital transistor

The trigger was routed to both the Shutdown-bar transistor on the EVKit, and the external trigger input on the vector signal analyzer. This arrangement allowed for direct correlation between the on/off trigger pulse and measurement data start point.

The vector signal analyzer was configured to display power (dBm in 1MHz resolution bandwidth) vs. time and the time scale was referenced from the trigger pulse. This method produced the result as shown in Figures 4 and 5. Note that the X-axis (time) is referenced directly to the same trigger event that enables the MAX2644 without any time delay, and the 'off' trigger occurs 62.5µs later on the same plot.

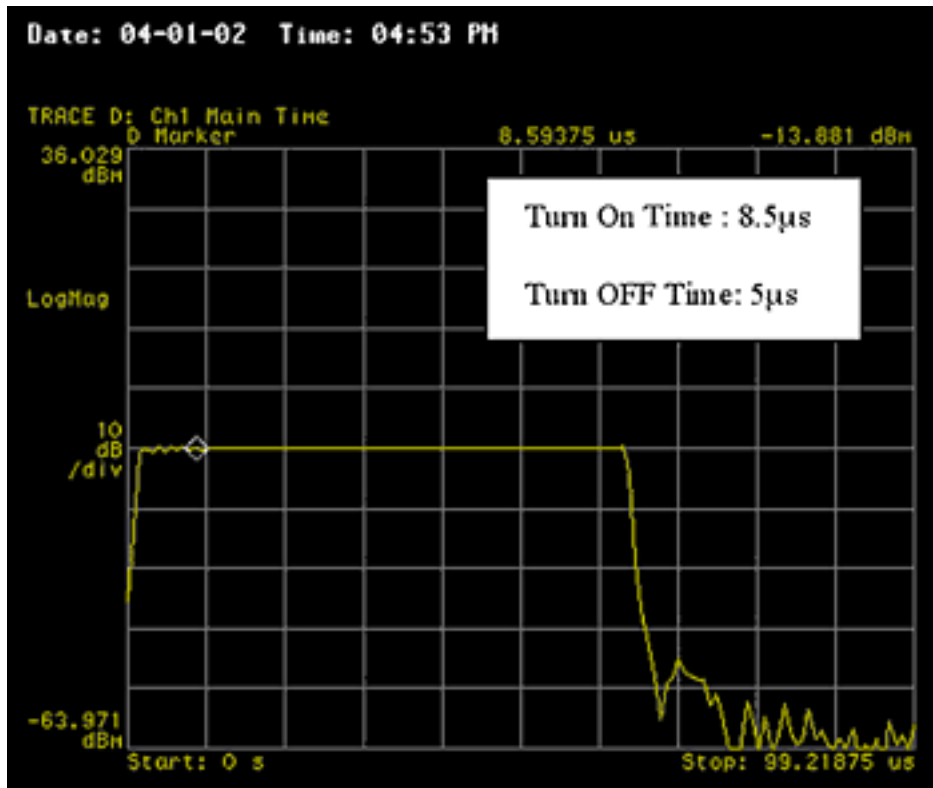

Figure 4. Pout vs. time (10dB/div)

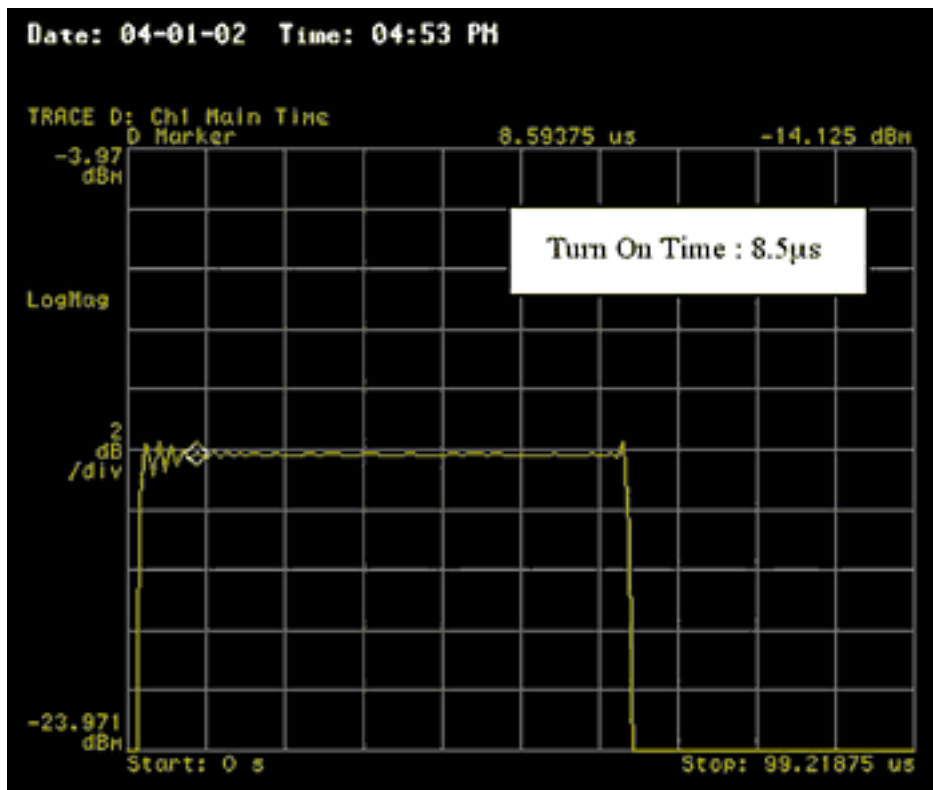

Figure 5. Pout vs. time (2dB/div)

More Information

MAX2644: [QuickView](#) -- [Full \(PDF\) Data Sheet](#) -- [Free Samples](#)